

# 3315B

## BS/CS DIGITAL SIGNAL GENERATOR



Type List

Type	Specifications
3315B-001	Standard
3315B-002	Standard + Noise Unit

### General

This unit is BS/CS (DVB-S) digital broadcasting signal generator corresponding to the technical condition of satellite digital broadcasting system using radio wave of frequency of more than 11.7GHz and less than 12.2GHz in the technical condition relating to digital broadcasting system "that is a part of "Telecommunication Technology Deliberative Assembly Consultation No. 74"". By selecting BS/CS system, coding process of ISDB-S System or DVB-S System is made and modulated signal is generated.

Wider range of symbol rate setting is possible and switching of master operation/slave operation of clock reference is possible. Also, synthesized frequency up-converter is equipped, so that signal corresponding to setting channel can be obtained.

By equipping optional noise generator, setting of C/N or Eb/No can be done easily.

By combining with Eiden's digital transmission tester 7705A-003, BS/CS measuring system is configured which allows several measurements, such as BER measurement, reception characteristics of hierarchy transmission and etc.

### Features

- Signal corresponding to ISDB-S/DVB-S coding system is output by system switching.
- Selection of parallel (LVDS) or serial (TTL/ECL) is possible for input interface.  
When serial is selected, PSYNC or SFSYNC signal is needed in case of BS system.
- Input format  
BS system : Stream framed with TMCC after transmission multiplexing of packet length of 204 bytes.  
CS system : Selection for TS packet length of 188 bytes or 204 bytes is possible.
- Symbol rate can be set in step of 1Hz and is corresponded to following range depending on system.  
System setting [BS] : 20 Msymbols/s ~ 30 Msymbols/s  
System setting [CS] [TEST] : 500 Msymbols/s ~ 30 Msymbols/s
- Internal/External switching for reference clock is possible. (External : TS input clock is reference)
- Function to pass each FEC process of main signal and TMCC is provided (ON/OFF of Interleave, Energy Dispersion, Reed-Solomon process is possible). Also, by system setting [TEST], data are input to inner encoder (Convolution Encoder) directly and signal corresponding to setting coding rate and modulation system can be output.
- Synthesized frequency up-converter is equipped and setting of channel in frequency range of 900MHz ~ 2200MHz is possible.
- By equipping optional noise generator, setting of C/N or Eb/No is done easily.
- Operation is done easily by liquid crystal display on panel
- GPIB interface for controlling is equipped as the standard.

### Composition

Main Unit	1
Dimensions	425(W) × 149(H) × 530(D) mm (Excluding projections)
Weight	Approx. 22 kg
Accessories	
Power Cable (Including 3pin - 2pin converter)	1
Rack Mount Adapter	1set
Instruction Manual and Test Result Sheet	1
Power Source	
Input Voltage Allowable Range	: AC90V ~ AC250V (50Hz/60Hz)
Power Consumption	: Approx. 200VA

### Operating Environment

Temperature	: +5 ~ +40
Humidity	: 45% ~ 85%RH (No dew generation)

### Rating

#### • Symbol Rate

System Setting [BS]	: 20 Msymbols/s ~ 30 Msymbols/s
System Setting [CS] [TEST]	: 500 Msymbols/s ~ 30 Msymbols/s

#### • Reference Clock

Setting of operation reference clock of this unit  
Slave operation : Operation by clock from setting input port.  
Note) In case that continuous operation with slave operation is made, refreshing of memory once every 2 months is needed.  
(Turn power off once, and turn power on again)  
If refreshing is not made, data are cut once, but after that, operation returns to normal.

Master operation : This unit is to be reference of clock.

Input signal should be synchronized in frequency with clock output of this unit.

#### • Serial Clock Input

BNC-R 1 route  
This is used as sync. clock of serial data input reception.  
In case that serial input port is set at the time of slave mode operation (CLK :[EXT]), this is used as master clock.  
Input Level : TTL/ECL can be selected all in gear.  
TTL is 50 GND termination and ECL is 50 -2V termination  
Input Frequency [BS] : Decided by symbol rate.  
 $2 \times \text{SYMBOL CLK} \times (51/52)$   
Input Frequency [CS] : Decided by symbol rate, coding rate and input format (188 or 204).  
 $2 \times \text{SYMBOL CLK} \times R \times (188/204)$   
R = coding rate  
Input Frequency [TEST] : Decided by symbol rate and coding rate.  
TC 8 PSK :  $2 \times \text{SYMBOL CLK}$   
QPSK :  $2 \times \text{SYMBOL CLK} \times R$  (Coding rate, R = 1/2)  
BPSK :  $2 \times \text{SYMBOL CLK} \times (1/2) \times R$  (Coding rate, R = 1/2)

#### • Packet Sync. Signal Input

BNC-R 1 route  
(SFSYNC) Valid when sync. detection is [EXT] in system setting [BS].  
This is used as super frame sync. detection signal of BS serial input. Only period of SFSYNC (8 bits) of data formed serial frame is to be high.  
(PSYNC) Valid when sync. detection is [INT] in system setting [BS], and is [EXT] in system setting [CS].  
This is used as packet sync. detection signal of TS serial input. Only period of PACKET SYNC (8 bits) of serial TS is to be high.  
Input Level : TTL/ECL can be selected all in gear.  
TTL is 50 GND termination and ECL is 50 -2V termination.  
Sync. Detection : Selection of process by internal sync. detection with super frame sync. (SFSYNC) or with packet sync. (PSYNC) signal is possible. (There are some conditions depending on system setting).  
Caution : In case of internal sync. detection in system setting [CS], existence of sync. bit sequence (47H) in packet cycle is not allowed except sync. bit sequence (47H) of TS. Also, in case of input format of 204, it is conditioned that sync. bit sequence (47H) is not continued for dummy data.

#### • Serial Data Input

BNC-R 1 route (MSB first input)  
System [BS] : Serial data of packet form buried TMCC with BS multiplexing stream.  
Refer to "Packet stream buried TMCC".  
System [CS] : Serial data of MPEG2 transport stream (TS) format.  
System [TEST] : Data stream (not depending on input format).  
Input data are input to inner encoder directly.  
Input Level : TTL/ECL can be selected all in gear.  
TTL is 50 GND termination and ECL is 50 -2V termination.  
Input Rate : Decided by symbol rate, coding rate and input format (188 or 204).  
In system setting [BS], input format is fixed to 204.  
Sync. Detection : Selection of process by internal sync. detection with super frame sync. (SFSYNC) or with packet sync. (PSYNC) signal is possible.  
Caution : In case of internal sync. detection in system setting [CS], existence of sync. bit sequence (47H) in packet cycle is not allowed except sync. bit sequence (47H) of TS. Also, in case of input format of 204, it is conditioned that sync. bit sequence (47H) is not existed in packet cycle for dummy data.  
In system setting [BS], super frame sync. detection is made by (SFSYNC) signal in case that sync. detection is made by external and by (PSYNC) signal in case that sync. detection is made by internal respectively.

Input Format 1 : TS 188 Format  
 Transport stream of packet length of 1504 bits.  
 1 packet = 188 bytes = 1504 bits

Input Format 2 : TS 204 Format

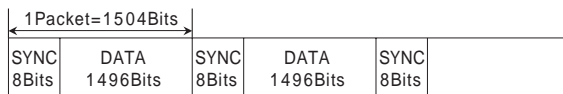

Transport stream of packet length of 1632 bits.  
 1 packet = 1504 bits + 128 (dummy data) bits = 1632 bits  
 Sync. bit sequence (47H) should not continue periodically for dummy data.

• Parallel Input

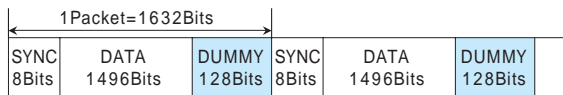

Dsub-25 (Female) 1 route  
 Interface LVDS conforming to DVB parallel specifications  
 (Conforming to TIA/EIA-644)

• System [BS]

Input Format : Packet stream with TMCC after transmission route multiplexing.  
 Input Rate : Byte rate of transmission route multiplexing of  $2 \times \text{SYMBOL CLK} \times (51/52) \times (1/8)$   
 Sync. Detection : PSYNC signal specified for DVB parallel port or format replaced PSYNC with SFSYNC. Selection is possible for external sync. detection by super frame sync. (SFSYNC) or internal sync. detection process that detects unique word by packet sync. (PSYNC) signal.  
 Data valid period is judged by DVALID signal.  
 Input Format : 204 Format  
 Packet stream with TMCC after transmission route multiplexing of packet length of 204 bytes (Refer to following figure).  
 1 packet = 188 bytes + 16 (dummy data) bytes = 204 bytes

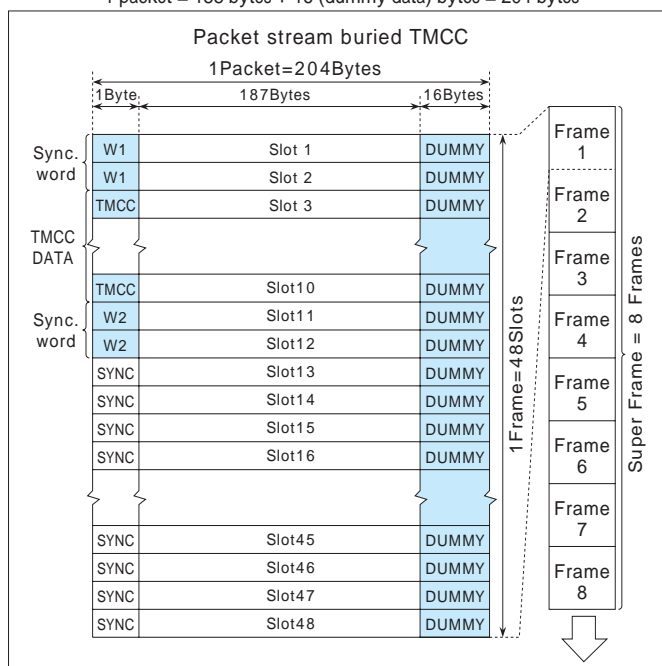

• System [CS]

Input Format : MPEG-2 transport stream  
 Input Rate : TS byte rate of  $2 \times \text{SYMBOL} \times R \times (1/8)$  or  $2 \times \text{SYMBOL} \times R \times (188/204) \times (1/8)$   
 Sync. Detection : Selection is possible for external sync. detection by PSYNC signal designated for DVB parallel port or internal sync. detection process that detects sync. byte [47H] from stream. Data valid period is judged by DVALID signal.

Input Format 1 : Transport stream 188 Format  
 1 packet = 188 bytes

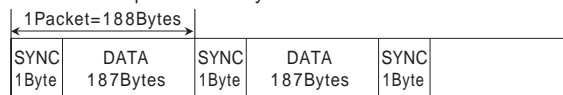

Input Format 2 : Transport stream 204 Format  
 1 packet = 188 bytes + 16 (dummy data) bytes = 204 bytes

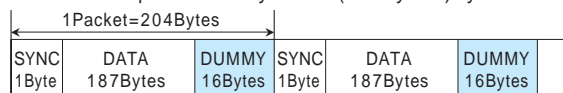

Coding Specifications

• System [BS] :

Coding process is done for stream buried TMCC data with BS transmission route multiplexing shown in parallel input format.  
 Judgment of super frame is made by buried sync. word, and following process is made for framed stream.  
 1) Addition of Reed-Solomon parity  
 2) Frame configuration  
 3) Energy dispersion  
 4) Block interleave  
 5) Convolution, Viterbi, Trellis  
 6) Burying phase reference burst signal  
 ON/OFF of process for 1), 3) and 4) is possible individually.

• System [CS]

Following process is done for transport stream.  
 1) Energy dispersion  
 2) Addition of Reed-Solomon parity  
 3) Convolution interleave  
 4) Convolution, Viterbi  
 ON/OFF of process for 1), 2) and 3) is possible individually.

• System [TEST] :

Following setting process is possible for input stream.  
 1) Transmission mode 8PSK  
 Trellis (R = 2/3)  
 2) Transmission mode QPSK  
 Convolution punctured coding  
 (R = 1/2, 2/3, 3/4, 5/6, 7/8)  
 3) Transmission mode BPSK  
 Convolution, conversion of parallel - serial  
 (Parallel 2 bits to serial 1 bit)

• Symbol Clock Input

BNC-R 1 route  
 Used as sync. clock of 3 bits symbol data input.  
 Connected with symbol clock output of 2711A.  
 Input Level : TTL 50 GND termination  
 Input Frequency : [BS] 20MHz ~ 30MHz  
 [CS] 500KHz ~ 30MHz  
 Should be synchronized with  $2 \times \text{SYMBOL CLOCK}$  of output of this unit.  
 Input frequency is the same with transmission symbol rate.

• Symbol Data Input

BNC-R  
 Input of 3 bits (8 values) symbol data.  
 3 inputs of BIT2 (MSB), BIT1 and BIT0 (LSB).  
 Input Level : TTL 50 GND termination  
 Input Rate : [BS] 20 Msymbols/s ~ 30 Msymbols/s  
 [CS] 500 Msymbols/s ~ 30 Msymbols/s  
 Should be synchronized with  $2 \times \text{SYMBOL CLOCK}$  of output of this unit.  
 Input rate is the same with transmission symbol rate.

• Clock Output

BNC-R (This is used when this unit is master operation)  
 Switching to serial clock or parallel clock is possible.  
 (SERIAL CLK) =  $8 \times (\text{PARALLEL CLK})$   
 Output Level : TTL/ECL can be selected all in gear.  
 For TTL, output is made with 50 line driver (equivalent to 74S140).  
 For ECL, open emitter output.  
 Output Frequency : In case of [BS], it is decided by transmission route multiplexing rate, that is  $2 \times \text{SYMBOL RATE} \times (51/52)$ .  
 In case of [CS], it is decided by TS rate, that is symbol rate, coding rate and input format (188 or 204).  
 $2 \times \text{SYMBOL CLK} \times R \times (188/204)$  (R = coding rate)

• 2 x Symbol Clock Output

BNC-R 1 route  
 This unit is to be clock master.  
 Connected to  $2 \times \text{SYMBOL CLOCK}$  input of 2711A.  
 Output Level : TTL (Output is made with 50 line driver (equivalent to 74S140)).  
 Output Frequency : [BS] 40MHz ~ 60MHz  
 [CS] 1MHz ~ 60MHz  
 (2 times of symbol rate)

• Wave Form Reform

Cosine Roll-off : = 0.35  
 Root ON/OFF is possible.

• Modulation Method

PSK modulation by phase mapping of 3 bits (8 values).  
 Function of modulation off, CW and 2 CARRIER output is provided.

• IF Signal Input/Output

BNC-R 1 route, normally connected with U Link (BNC-UPA).  
 Center Frequency : 140 MHz  
 Level : - 10dBm/50 (No AGC at input stage)

• RF Converter

Output Connector : N-R 1 route  
 Frequency Setting Range : 900MHz ~ 2200MHz  
 Frequency Setting Resolution : 10kHz  
 Level Setting Range : + 10dBm ~ - 82dBm

In case of adding noise, output level setting should be less than - 10dBm with AGC OFF.  
 Level Setting Resolution : 0.1dB  
 Output Impedance : 50  
 Band Width : Center Frequency  $\pm$  30MHz  
 AGC Function : Average  
 Function of AGC OFF (MGC Mode) is provided.  
 Relation between IF and RF : Reverse

• **Characteristics of RF Converter Part**

Output Frequency Accuracy : Within  $\pm 2 \times 10^{-7}$  against setting value  
 Frequency Response : Within  $\pm 1$ dB (BW <  $\pm 30$ MHz)  
 2 signals 3rd Distortion (IM3) : Less than - 50dB (Output Level = +7dBm/each)  
 Spurious : Less than - 50dB  
 C/No : Less than - 127dBc/Hz @2MHz OFFSET  
 SSB Phase Noise : Less than - 95dBc/Hz @10KHz OFFSET  
 Less than - 114dBc/Hz @100KHz OFFSET

• **Output Level Accuracy :**

Output Level Setting	Accuracy : AGC ON	Accuracy : AGC OFF
+ 10dBm ~ - 39dBm	$\pm 1.5$ dB	$\pm 3.5$ dB
- 40dBm ~ - 69dBm	$\pm 2.0$ dB	$\pm 4.0$ dB
- 70dBm ~ - 82dBm	$\pm 3.0$ dB	$\pm 5.0$ dB

• **GPIB**

GPIB Connector 1 route  
 Conforming to IEEE488  
 (Under remote control, in case that unit is used for a long time by switching setting frequently, please consult with Eiden separately)

Option

• **Noise Generation Unit (OPTION No. -002)**

Switching of noise ON/OFF is possible. Noise is added on IF = 140MHz band of this unit.  
 Following specifications are assuming that noise is added on IF signal of this unit.  
 Setting Range of C/N, Eb/No : - 5 ~ + 30dB  
 Accuracy of C/N, Eb/No :  $\pm 0.5$ dB max.  
 $\pm 0.1$ dB typ.  
 (@25 : C/N, Eb/No = - 3 ~ 17dB)

Setting Resolution : 0.1dB

Noise Bandwidth :

Eb/No Mode : 18MHz typ.  
 @BREb/No < 4MHz  
 125MHz typ.  
 @BERb/No 4MHz

BERb/No is calculated by following list.

System	BERb/No
CS	$2 \times SR \times R \times IF$
TEST 8PSK	$2 \times SR \times (2/3)$
TEST QPSK	$2 \times SR \times R$
TEST BPSK	$2 \times SR \times (1/2) \times (1/2)$

BERb/No : Converted bit rate to be applied to calculation of Eb/No  
 SR : Symbol rate  
 R : Coding rate (1/2, 2/3, 3/4, 5/6, 7/8)  
 IF : Interface format (187/204, 184/204)  
 (Valid data ratio in packet)

C/N Mode : 125MHz typ.

System Band Width : 2.7MHz ~ 36MHz

Setting Resolution : 0.01MHz

• **RS422 Parallel Interface (OPTION No. -010) Specifications**

Electrical specifications of Dsub connector interface on rear side are to be RS422.  
 (LVDS specifications are to be RS422 specifications and no change of pin assignment)  
 Dsub25 (Female) PARALLEL INPUT : RS422  
 Dsub9 (Female) CLK OUTPUT : RS422

# 9102A

## BS/CS CHANNEL MIXER



### General

This unit is exclusive mixer of IF TV signal for digital satellite broadcasting (BS/CS digital broadcasting). (Max. 10 waves)  
 Mixing is made with low loss without influencing each input channel and they are taken out as 1 output and fed to signal line.

### Composition

Main Unit ..... 1  
 Specifications are slightly different depending on number of input channel, so that please consult with EIDEN.

### Rating

- **Input Channel** Designated channel
- **Input Impedance** 50  $\Omega$ -R
- **Output Impedance** 50  $\Omega$ -R
- **Input Level** Less than 1W for each channel
- **Input VSWR** Less than 1.3 for each channel band width
- **Frequency Response** Within 0.5dB in each channel band width
- **Isolation between channels** More than 20dB
- **Mixing Loss** Depending on number of input channels